

Brian Ashley Jones

Stage Plot / Tech Requirements for Acoustic / Electric Duo

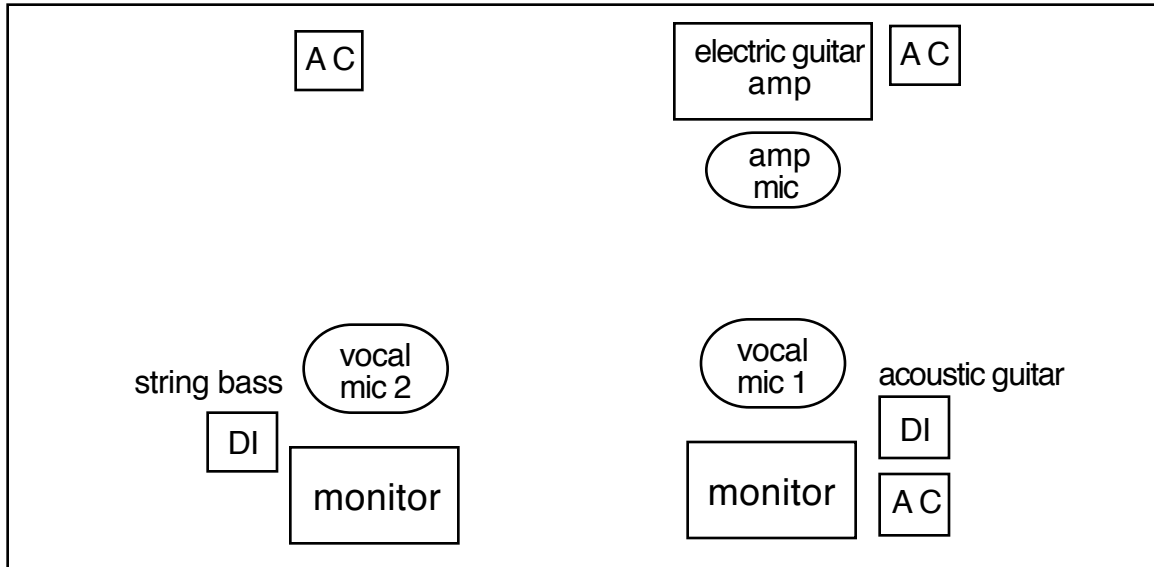

INPUTS

- | | | |
|---|-------------------------|------------------------------------|
| 1 | lead vocal | SM-58 with boom stand |
| 2 | backing vocal | SM-58 with gooseneck or boom stand |
| 3 | acoustic guitar | DI |
| 4 | electric guitar amp mic | SM-57 with stand |
| 5 | string bass | DI |

OTHER REQUIREMENTS

minimum stage clearance from floor to ceiling (for string bass) = 7ft

separate monitor mixes

guitar amp provided by artist (Fender Deluxe Reverb tube amp)

CONTACT INFO

to advance the show, contact Brian Ashley Jones:
404-277-1744
brian@brianashleyjones.com